



CAM for Wire EDM

www.gibbscam.com

GibbsCAM Wire EDM, powered by OPTICAM is designed to handle the most demanding programs while being easy to use and supporting the programming of 2D through 4-axis CNC wire EDM machines.



Powerful

Programs all of your CNCs to machine simple and complex parts.

Easy

Consistent and intuitive shop-friendly graphical user interface for quick learning and fast navigation.

Flexible

Provides multiple ways for CNC programmers to approach machining operations.

Productive

Faster programming, faster machining, and higher throughput.

Grows with You

GibbsCAM stays current with the latest machine tool technology. You won't need another CAM system when you get new machines, and you can add options to increase functionality as you need them.

Lower Programming Cost

Beyond a flat interface that eliminates wasted menu-seeking user actions, GibbsCAM provides many automated features to streamline the CNC programming process.

Accuracy and Speed

GibbsCAM gets more programs done faster with higher accuracy, better reliability, and faster cycle times. You'll spend less time testing and proving programs on machine and get more parts out the door.

“ GibbsCAM has all the tools we need. As we see challenges in the work ahead of us, we feel comfortable that GibbsCAM is going to be there for us. GibbsCAM handles it all. ”

— Rodney Babcock, President & CEO of Next Intent

Designed to Simplify

GibbsCAM is designed to simplify the complex. It has a modeless graphical user interface that lets the user perform any function at any time, without pursuing an endless hierarchy of menus. Users can quickly jump from toolpath verification to part design or tool definition and back. Icons that reflect shop procedures make operations easy to identify and fast to navigate. These features make learning fast and easy for the new user and highly efficient for the experienced.

The user interface is consistent across the product line. This means that when you add capabilities for new machine types or machining processes, the look and navigation do not change. So, programmers and machinists get productive with new modules quickly.

Advanced Programming Made Easy

GibbsCAM's intuitive graphical user interface provides seamless access to both turning, milling, and wire EDM capabilities. GibbsCAM's associativity allows operations to be updated easily when modifications are made. Factory-supplied post processors output multi-flow NC code complete with utility operations and sync codes.

Feature Recognition

GibbsCAM Wire EDM, powered by OPTICAM can automatically analyze your solid or wireframe part, locating wireable geometries and automatically producing appropriate machining features. Control undercuts, conicity, hole filtering, and other parameters to get exactly the results you need. The results are immediately displayed graphically, conforming to model changes in real time.

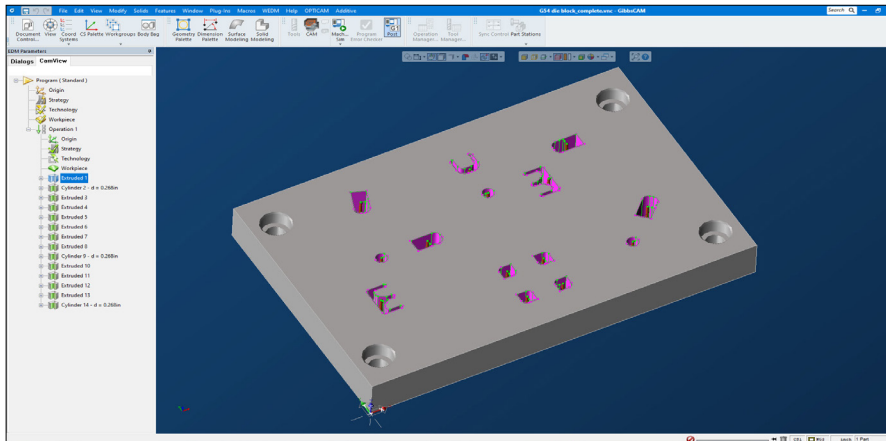

Pocketing

To avoid manual interventions and machine downtimes, efficient pocketing of geometry without creating slugs is often needed. GibbsCAM offers special cylindrical and conical pocketing strategies for this purpose.

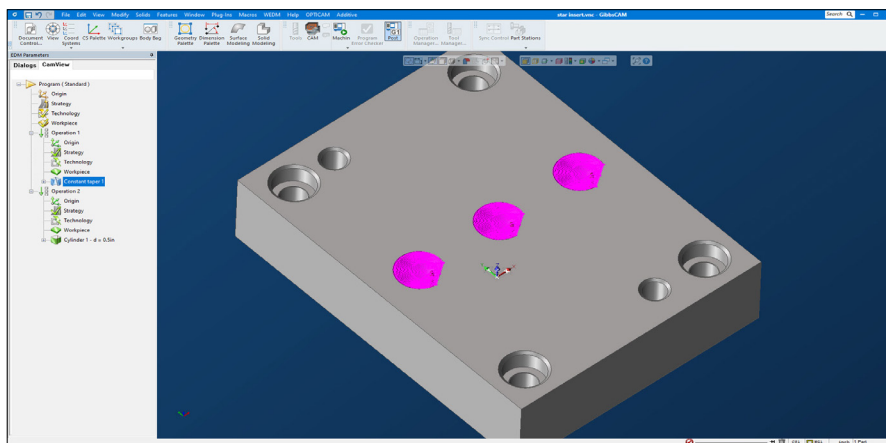

Start Holes and Tags

Start holes are selected automatically for best machining conditions, or you may specify them manually to conform to material conditions or other requirements. Gluestop tags or bridges can also be positioned and cut automatically or manually. Lead on/off can be configured as straight, angular, arc, or meander, with controlled overtravel. Automatic threading and cutoff of the wire is supported, including diagonal threading.

MACHINING FUNCTIONS

- Cylindrical machining
- Constant and variable taper, also on cylindrical parts
- Ruled surface machining with automatic synchronization
- Inclined machining
- Collar machining
- Subsequent positioning of a taper despite cylindrical construction (constant, variable or as collar machining)
- Pocketing
- Variable Reference Plane Height
- Automatic threading and cutoff of the wire
- Diagonal threading
- Automatic positioning
- Automatic clustering of identical geometries
- Multi part programming

Events and Segments

Events can be placed at any position of a feature. Comments or machine instructions, such as M-codes, G-codes or arbitrary NC sets, can be inserted at these points. Furthermore, individual features can be split up into several segments. For each segment the number of cuts, offset values, lead on/off technologies, or a partial pocketing can be set separately.

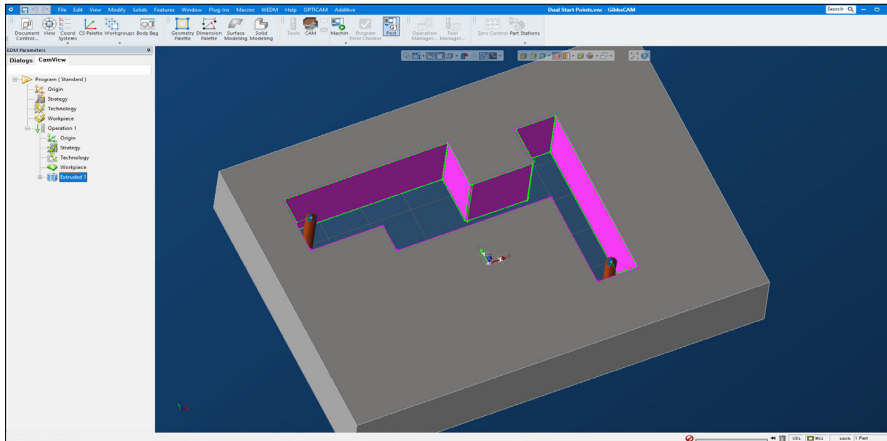

Operation Strategies

GibbsCAM contains all machining strategies required for the efficient and safe operation of wire EDM machines. Strategies include: Attended and unattended day and night operations, Punch strategies, Reverse cutting, Automatic cutting off of slugs, and User defined templates.

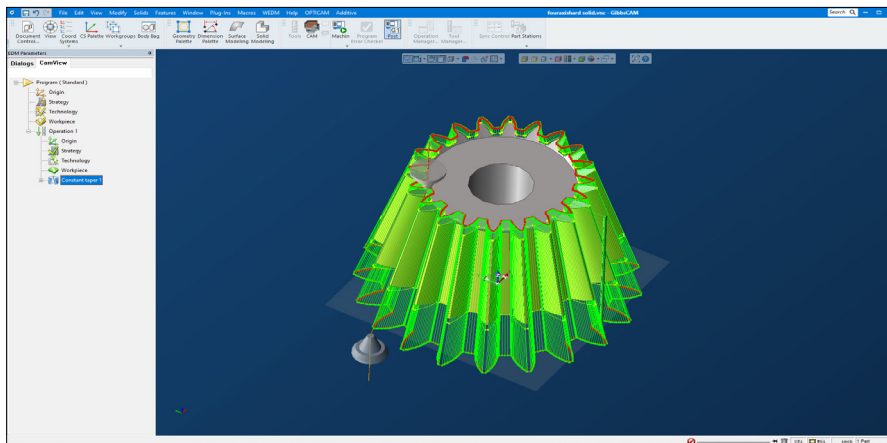

TECHNOLOGY DATABASE

GibbsCAM offers original technology databases for all major manufacturers, including:

- AC CUT 20 / 30 / 200 / 300 / 400 / E350 /E600
- Mitsubishi
- Fanuc
- Sodick
- Makino
- ONA
- Seibu
- Excetek
- AccuteX
- Joemars

Post Processors

GibbsCAM has been developed in cooperation with leading machine manufacturers and is being continuously adjusted to the latest wire EDM machine functions.

Through its worldwide reseller network, GibbsCAM provides fast, personalized technical support to ensure your production is continuous and your productivity is uncompromised.



Nordic distributor: Fructus Data AB, Sweden | www.fructus.se | +46 8 59411630
Americas: +1 800.654.9399 | www.gibbscam.com | Email: info@gibbscam.com