



# GibbsCAM GO MTM

Simply Powerful Multi-Task  
and Swiss Machining

[www.gibbscam.com](http://www.gibbscam.com)

# GO

## GO Multi-Task Machining

GibbsCAM GO MTM is specifically designed to address the CNC programming requirements of the most complex machine tools that combine both milling and turning. GibbsCAM GO MTM provides powerful programming tools that are easy to learn and empower the programmer with the ultimate in flexibility and configurability.

Machining processes are easily defined with GibbsCAM's intuitive user interface that provides seamless access to both turning and milling capabilities. Full associativity ensures that machining operations are automatically updated when changes are made to the program. Factory-supplied post processors output multi-flow NC code complete with utility operations and sync codes, maximizing your machine investment and reducing run times.

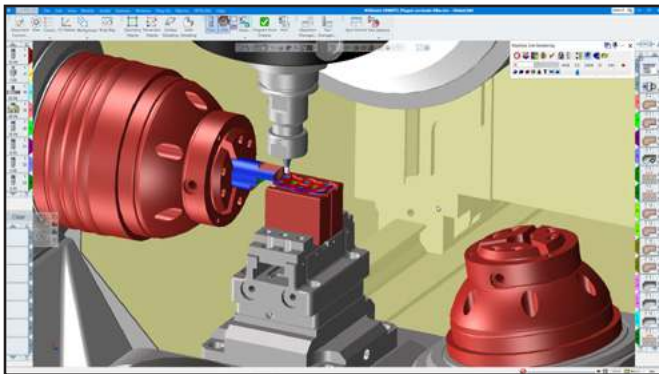

Program machines with all types of axes and tools

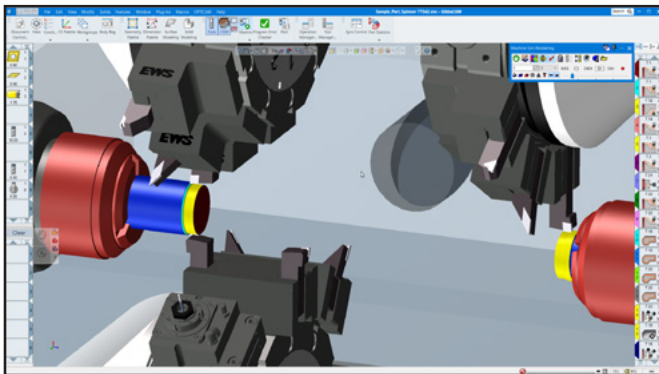

Program machines with any number of turrets and spindles

### Universal Kinematic Machine Technology

GibbsCAM Universal Kinematic Machine (UKM) technology allows users to program, simulate, and post process for machines with any number of axes and flows.

- Accurately simulate all the machine components and capabilities of any machine
- Generate complete, error-free post processed output that maximize your machine capabilities
- Scalable technology that is ready to support future machine solutions

### Multiple Turrets and Spindles

Today's multi-task machine tools incorporate a wide variety of spindle and turret combinations with no end in sight. A two spindle, two turret configuration is common with machines with more than two spindles or turrets becoming increasingly common. With GibbsCAM MTM, users can program machines that have any number of turrets and spindles.

### Machine-Specific Setup

Multi-task machine tools represent some of the most diverse machine tool configurations available today. With GibbsCAM MTM, your machine tool's specific configuration is captured by GibbsCAM's factory-supplied settings so that you are accurately programming all its capabilities. This way you can be sure that you are taking full advantage of your machine tool for maximum productivity.

## Intermediate Tooling Support

Tooling is more manageable, simulation more accurate and programming easier, with more accurate tool placement and orientation. Fixed and live tooling is defined, located and oriented on the machine tool using GibbsCAM's graphical interface.

- Support for toolblocks (adapter blocks, holders for tool holders, right-angle and adjustable heads and flash tooling) with toolblock library
- Support for fixtures (chucks, tailstocks, steady rests and other work holding) including fixture library
- Simplifies programming through easy and accurate placement and orientation of tools

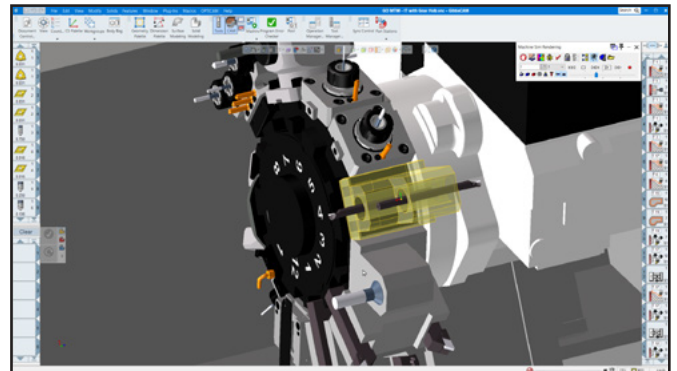

Intermediate tooling provides more accurate simulation of cutting motion

## MTM Sync Manager

GibbsCAM MTM's Sync Manager provides an easy to understand, intuitive, graphical interface allowing you to focus on optimizing your process. The Sync Manager handles all the underlying complexities for you.

- Displays multiple, parallel process flows
- Calculate operation times to optimize machine moves
- Control non-cutting machine moves
- Automatically check for invalid operations or synchronization

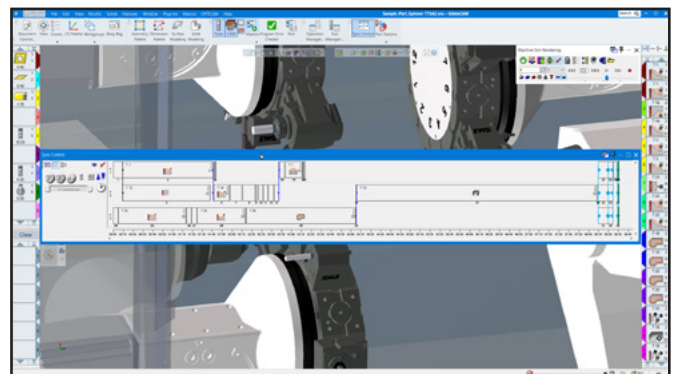

Easily visualize flows and machining processes with GibbsCAM Sync Manager

## Machine Simulation

An extension to the GibbsCAM integrated Cut Part Rendering visualization/verification capability, Machine Simulation uses animated machine tool models to identify any program errors before they cause costly mistakes on the shop floor.

## Swiss-style Machine Tool Programming

Swiss-style machine tools are becoming extremely popular, especially for ultra-high precision parts and complete lights out machining. GibbsCAM MTM supports Swiss-style multi-task machine tools and provides an easy-to-use tool for programming these complex devices. Utilizing an intuitive sync manager in addition to UKM technology, GibbsCAM is the powerful and easy-to-use solution for programming Swiss-style machining centers.

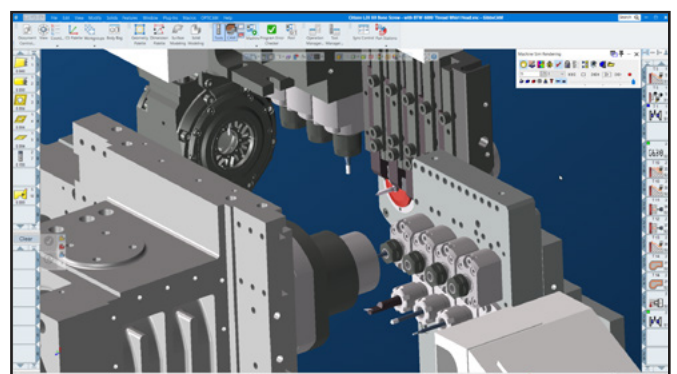

Program the most complex Swiss-style machines with the same easy-to-use GibbsCAM interface.

## Utility Operation Support

GibbsCAM MTM supports the entire range of utility operations used by your machine tool, providing full control all the way to posted output. Fully controlling non-cutting moves ensures that you fully utilize your MTM machine tool to maximize your return on investment.

- Sub-spindle programming
- Bar feeders and part catchers
- Full off-part turret control and placement

## Integrated Process Rendering

GibbsCAM MTM's integrated simulation allows you to fully verify your programs including multiple tools cutting at the same time, on-screen, reducing the risk of gouges and collisions.

- Visual gouge checking
- Check efficiency of cutting and non-cutting moves
- Simultaneously visualize multiple workflows

## In-house Development of Post Processors

Our in-house team of expert post processor developers ensure that you get posted output specifically formatted for your machine tool that fully supports its capabilities. With factory-supplied posts, you do not spend your time figuring out how to post output for your machine tool - we take care of that for you.

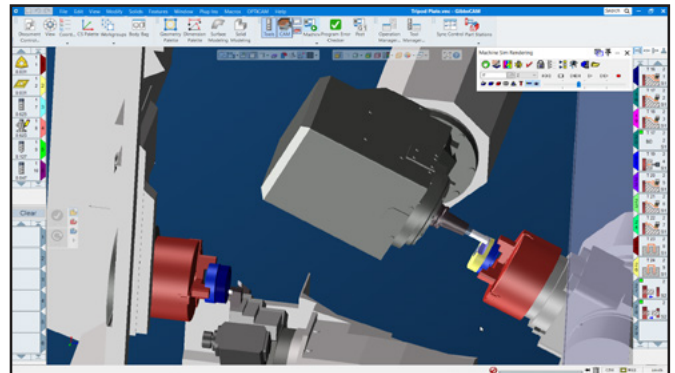

Program machines with indexable sub-spindles

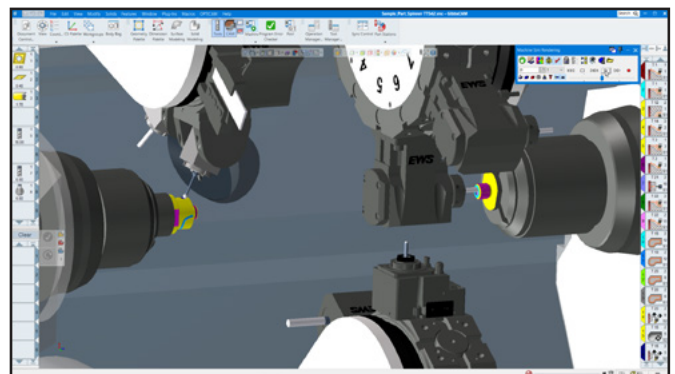

Fully verify NC programs on-screen, reducing the risk of gouges and collisions



**Download latest version:**

[www.gibbscam.com/downloads](http://www.gibbscam.com/downloads)



**Contact your dealer:**

[www.gibbscam.com/reseller-finder](http://www.gibbscam.com/reseller-finder)



**Request Free 30-day trial:**

[www.gibbscam.com/explore-gibbscam](http://www.gibbscam.com/explore-gibbscam)



## Add-On Options

As your shop grows, or replaces machinery, GibbsCAM helps you grow. Multiple options integrate with the same familiar, intuitive interface allowing you to program any part for efficient machining on any machine.

- 5-Axis Simultaneous Milling
- Multi-Blade and Porting
- Tombstone Management Systems (TMS)
- Wire EDM for 2D to 4-axis
- On-Machine Probing



Nordic distributor: Fructus Data AB, Sweden | [www.fructus.se](http://www.fructus.se) | +46 8 59411630  
[www.gibbscam.com](http://www.gibbscam.com) | Americas: +1 800.654.9399 | Email: [info@gibbscam.com](mailto:info@gibbscam.com)